

Ann Lin^{1,2}
 Frøydis Sved Skottvoll^{1,3}
 Simon Rayner^{1,4}
 Stig Pedersen-Bjergaard⁵
 Gareth Sullivan^{1,6,7,8,9} 
 Stefan Krauss^{1,10}
 Steven Ray Wilson^{1,3} 
 Sean Harrison¹

¹Hybrid Technology Hub-Centre of Excellence, Institute of Basic Medical Sciences, Faculty of Medicine, University of Oslo, Oslo, Norway

²Department of Genetics, Stanford University, CA, USA

³Department of Chemistry, University of Oslo, Oslo, Norway

⁴Department of Medical Genetics, Oslo University Hospital and University of Oslo, Oslo, Norway

⁵School of Pharmacy, University of Oslo, Oslo, Norway

⁶Norwegian Center for Stem Cell Research, University of Oslo, Oslo, Norway

⁷Department of Molecular Medicine, Institute of Basic Medical Sciences, University of Oslo, Oslo, Norway

⁸Institute of Immunology, Oslo University Hospital, Oslo, Norway

⁹Department of Pediatric Research, Oslo University Hospital, Oslo, Norway

¹⁰Unit for Cell Signaling, Department of Immunology and Transfusion Medicine, Oslo University Hospital, Oslo, Norway

Received May 3, 2019

Revised September 12, 2019

Accepted September 19, 2019

1 Introduction

Drug discovery and development is a lengthy and costly process that involves several preclinical stages, including target validation, hit to lead optimization, adsorption, distribution, metabolism, and excretion studies, pharmacodynamics stud-

Correspondence: Prof. Steven Ray Wilson, Department of Chemistry, University of Oslo, Post Box 1033, Blindern, NO-0315 Oslo, Norway

E-mail: stevenw@kjemi.uio.no

Abbreviations: EME, electromembrane extraction; ESCs, embryonic stem cells; HSCs, hepatic stellate cells; iPSCs, induced pluripotent stem cells; OTLC, open tubular LC; SLM, supported liquid membrane

Review

3D cell culture models and organ-on-a-chip: Meet separation science and mass spectrometry

In vitro derived simplified 3D representations of human organs or organ functionalities are predicted to play a major role in disease modeling, drug development, and personalized medicine, as they complement traditional cell line approaches and animal models. The cells for 3D organ representations may be derived from primary tissues, embryonic stem cells or induced pluripotent stem cells and come in a variety of formats from aggregates of individual or mixed cell types, self-organizing in vitro developed “organoids” and tissue mimicking chips. Microfluidic devices that allow long-term maintenance and combination with other tissues, cells or organoids are commonly referred to as “microphysiological” or “organ-on-a-chip” systems. Organ-on-a-chip technology allows a broad range of “on-chip” and “off-chip” analytical techniques, whereby “on-chip” techniques offer the possibility of real time tracking and analysis. In the rapidly expanding tool kit for real time analytical assays, mass spectrometry, combined with “on-chip” electrophoresis, and other separation approaches offer attractive emerging tools. In this review, we provide an overview of current 3D cell culture models, a compendium of current analytical strategies, and we make a case for new approaches for integrating separation science and mass spectrometry in this rapidly expanding research field.

Keywords:

Chromatography / Electrophoresis / Mass spectrometry / Organ on a chip / Organoid
 DOI 10.1002/elps.201900170

ies, and in vitro toxicity testing before the drug can proceed through the investigational new drug stage to clinical trials [1, 2]. Most experimental drugs fail before reaching clinical trials. Further significant termination of new drugs occurs during latter stages of clinical trials. Only around 10% of all drugs that enter phase I clinical trial succeed in obtaining the United States Food and Drug Administration approval while over half of the drugs tested in phase III trials spanning from 1998–2008 fail due to inadequate preclinical efficacy and drug toxicity [3, 4].

Numerous studies have highlighted culprits which are contributing to the low efficacy and high toxicity of drugs

Color online: See article online to view Figs. 1, 2, and 4 in color.

entering preclinical testing [5]. In particular, it has been pointed out that cells that are used in preclinical drug validation assays (e.g. immortalized cell lines and cancer cell lines) frequently do not reflect the physiology, complexity, and diversity of a corresponding cell in healthy humans. Cell lines have altered biochemical pathways due to the culturing process or the disease state of the donor from which they were derived. Mouse and other animal models better reflect the complexity of the human body, but their physiology diverges from the human state and they fail to capture the heterogeneity of the human population. In addition, the field lacks appropriate mouse models for a significant spectrum of human disease conditions. Finally, extensive animal experiments, as required for preclinical drug testing, raise ethical issues. Hence, there has been an increasing demand for developing novel experimental models that may help to better map potential patient responses to experimental drugs during preclinical drug development. A currently explored strategy in this direction is to increase the complexity of an *ex vivo* cellular system to better reflect aspects of the human physiology relevant to the drug discovery and validation process [6,7]. Hence, traditional 2D-cultivated cell cultures are expanded into barrier structures comprising of two cell layers that may include several cell types separated by a membrane, 3D structures that may contain a number of cell types in a specific spatial arrangement, and combined systems that comprise several cellular systems [7,8]. By combining the advances in cell engineering with microfluidic technology and lab-on-a-chip [9,10], different chip-based cell microenvironments have evolved and facilitated miniaturized *in vitro* studies over the past two decades [11,12].

Recent examples for cell barrier structures are lung-on-a-chip [13,14], and gut-on-a-chip systems [15,16]. Examples for 3D structures that may be relevant for drug testing are neural organoids [17,18], 3D muscle structures [19,20], liver organoids and liver-on-a-chip models [21,22], islets [23], and white adipocyte tissue-on-a-chip [24]. Examples for combined structures may be a gut-on-a-chip coupled to a liver-on-a-chip to model drug adsorption and metabolism [25], a liver-on-a-chip combined with a heart-on-a-chip to model cardio-toxicity [26], and a tumor-on-a-chip combined with components of the immune systems in fluidic compartments [27].

The biological material for barrier structures, 3D cultures, and multi-organ systems “on chip” can vary. Frequently, immortalized cell lines such as human hepatic (HepG2) cells, human intestinal (Caco-1) cells, or human vascular endothelial cells are used [25]. Such cell lines provide a controlled and reproducible source of biological material at the cost of compromised physiological activity. Cells can also be derived, either in a terminally differentiated state such as human hepatocytes, or as cells differentiated from adult stem cell pools such as mesenchymal stem cell derived chondrocytes, osteoblast, and adipocytes. Further promising source for functional cells are human embryonic stem cells (ESCs) and human induced pluripotent stem cells (iPSCs) [28]. Both stem cell types can in principle be differentiated into all types of cells present in the human body. However, many differenti-

ation protocols require further elaboration and differentiated cells or tissue derived from ESCs or iPSCs lack the maturity and physiological activity of adult tissue, and commonly lack the correct spatial arrangement that is characteristic of mature tissue [29]. Despite these pitfalls, iPSC technology not only allows for the creation of a representative system for functional organs, but – since iPSCs can be derived from any subject, control or diseased – it also enables genotypic personalization [6]. Hence, the field works towards exploring future preclinical drug testing on healthy and diseased 3D models with the perspective of allowing researchers to extrapolate how patients may respond to a plethora of drugs in a healthy state, and at various stages of their personal disease progression.

2 Drug development and disease modeling *in vitro*

There are many variations of 3D cell culture, though some are distinctly more organotypic than others, by virtue of being formed through developmentally recognizable stages [30], in contrast to aggregates or spheroids [31], while some lie between the two such as the liver buds from the Takebe group, a mixture of iPSC specified hepatic endoderm with cell lines condensed to mimic the early points in organogenesis [32]. A distinct subset of 3D cell culture, organoids are self-organized tissue systems derived from stem cells including iPSCs, ESCs, and *in vivo* derived progenitor populations. They can reflect much of the complexity of the organ they model, or present with certain aspects of the organ, for example producing only specific types of cells, i.e. LGR5 derived single cell liver organoids [33]. They can be distinguished from Organ-on-chip technology that relies on engineering specific complexity or features into the system, such as distinct spatial separation of different cell types and/or extra cellular matrices, in order to model a key organ or tissue function or subunit. An advantage of organoid cultures, compared to monolayer culture systems, is that it provides an environment allowing cell-cell interactions to be established, therefore mimicking the *in vivo* situation, such as the correct orientation and polarity of cells and formation of structures, where they begin to take on the properties of smaller tissue subunits. For example, a number of labs have produced cerebral organoids using PSCs, which recapitulate developmental processes and importantly the organization of a developing human brain including acquisition of cell polarity and distinct neuronal zones [34–37]. While intestinal organoids present with polarized columnar epithelium containing enterocytes, goblet, Paneth, and enteroendocrine cells, they also develop characteristic villus structures and proliferative crypt zones expressing stem cell markers, which are representative traits of the human intestine [38–40]. Hepatic organoids have been demonstrated that form both hepatocytes and cholangiocytes and their organization into physiologically relevant structures in a single protocol, where non-organoid derivation of these cell types requires separate protocols [41].

In general, 3D cultures containing multiple cell lineages have advantages over co-culture based on monolayer systems. An example is demonstrated by Coll and colleagues' cultured spheroids consisting of iPSC derived hepatic stellate cells (HSCs) and the immortalized "hepatocytes like" cell line HepaRG cells. They observed a quiescent phenotype from the HSCs in the aggregates as well as an increased hepatocyte specific gene expression in the HepaRGs [31]. These co-cultures can then be used to model liver fibrosis caused by activation of the HSCs in the liver, which can lead to cirrhosis and hepatocellular carcinoma. Treatment of these co-cultures with fibrogenic and hepatotoxic compounds resulted in signs of fibrosis such as HSC activation, extracellular matrix secretion, and deposition which are absent from mono-cultures of these cells, highlighting the interaction between the two cell types within the spheres and showing their use as disease and toxicity models.

Many diseases, however, would be unsuitable for modeling in an aggregate system, such as the one used above, as they are caused by changes in the arrangement of cells or 3D structure of solid organs during development. Here, the self-organizing complexity of organoids is a necessity. For example, hepatobiliary organoids were used in a study by Guan and colleagues to model Alagille syndrome, which presents with impaired bile duct formation and many facets of biliary atresia in patients. The study used iPSCs harboring a mutation in the JAG1 gene to generate hepatobiliary organoids and the model recapitulated many of the defects observed in patients including impaired biliary development, revealing that it is not caused by immune mediated damage [41].

To develop and utilize 3D organoids and organ-on-a-chip technology to their full potential, it is important to understand the current development state of the technology and the analytical possibilities that it provides. In this review, we will discuss how extraction and separation science (based on chromatography and electrophoresis) and MS techniques may become central tools in tomorrow's drug discovery and validation studies in microphysiological systems. As of today, the coupling of, e.g. electrophoresis and organoids/organ-on-a-chips are hardly described in literature, so this review is intended to serve as an introduction to new possibilities.

Since organoid technology is at a relatively early stage in its development, the accepted characterization and analysis parameters for organoids are currently evolving. To date, a number of accepted molecular, cellular, and next generation analyses are carried out, including: reverse transcription-quantitative polymerase chain reaction against established developmentally relevant genes, western blot analysis, microscopy including confocal, spinning disc and light sheet, flow cytometry, ELISA and now single cell RNA sequencing is becoming the bench mark (Fig. 1). These are used to study the development and validate the differentiation of 3D cultures as well as to assess the effects of assays in the context of disease modeling, etc. However, bioanalytical techniques such as chromatography, electrophoresis, and MS are still little used in organoid analysis. Below, we discuss opportunities for these approaches.

3 The small size of an organoid: challenges and opportunities for micro-separations

Organoids are typically very small, e.g. in the millimeter scale or below. Hence, there are significant challenges in performing sensitive analysis of organoids, in regards to both the organoid itself, and perhaps even more challenging, the minute secretions of an organoid. Conventional LC–MS systems will arguably pose difficulties in organoid analysis, as they are primarily developed for far larger sample sizes. Specifically, conventional LC–MS systems often feature separation columns that have 1–2.1 mm i.d.. Although these columns are robust and reproducibly manufactured, there lies a disadvantage in that the wider the i.d., the more a sample is diluted during chromatography. This can be detrimental to sensitivity when a concentration-sensitive detection system such as electrospray-MS is employed [42]. Sample dilution does not have to be an issue when ample amounts of sample are available, but when very limited samples are to be processed, a reduction in column i.d. may be preferred. This is one of the reasons why proteomics is often performed with narrow LC columns, e.g. the nano-LC format (about 0.05–0.1 mm column i.d.). It can however be mentioned that larger column i.d. are also used for proteomics, in compromises between sensitivity and robustness, but also because of improvements in ESI hardware. In routine drug analysis laboratories, narrow column i.d. are often regarded as being impractical, due to the difficulties of handling the small-scale hardware and nL– μ L/min flow rates. However, to perform analyses related to organoids, narrow LC columns may be the only choice (and hence an important application area for the technology). Also, organoid/organ-on-a-chip researchers are already working with low flow fluidic systems, so the realities of narrow LC may be simpler to accept, as was the case in proteomics.

Nano-LC–MS based proteomics is a beneficial tool in organoid analyses typically relying on the analysis of peptides enzymatically digested from their proteins of origin ("bottom-up" proteomics) [43]. When additional pre-fractionation techniques are employed, nano-LC–MS analyses have led to the identification and quantification of over 7000 proteins in different organoid materials (e.g. intestinal-, pancreatic-, mammary- and tumor and healthy colon organoids) [44–47]. For example, Cristobal et al. assessed the proteomic heterogeneity between patient-derived human colorectal tumor and healthy organoids using nano-LC–MS. The proteomic study recapitulated previous genetic experiments demonstrating that down-regulation of the protein MSH3 correlates with colorectal cancer tumorigenesis. Furthermore, the results from the nano-LC–MS analysis also revealed discrepancies between proteomic and transcriptome trends within patient-derived human colorectal tumor. This is illustrated by results from the nano-LC–MS experiment revealing down-regulation of proteins such as PMS2, MSH3, MLH1, and RPL22 in colorectal cancer cells which were not observed from previous transcriptomic studies [47]. Thus, not only did the study demonstrate the bio-variability between individuals, but it

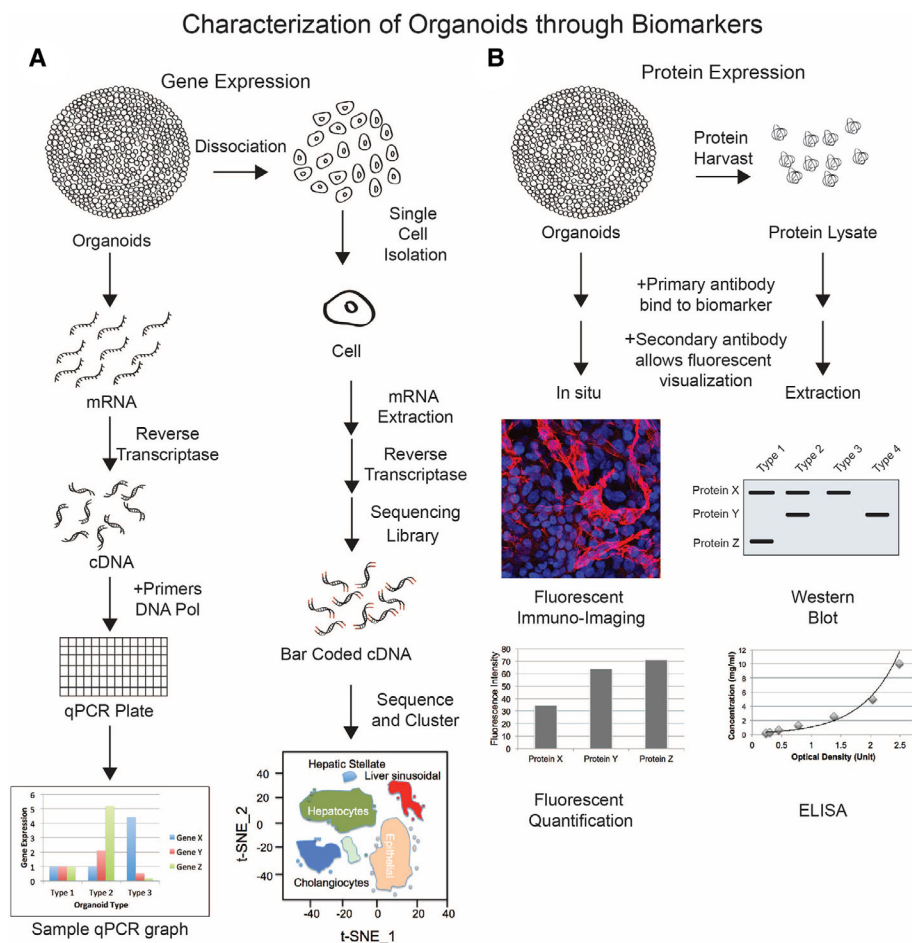

Figure 1. (A) Schematic of transcriptomic techniques, qPCR and single cell RNA sequencing, used in the characterization of organoids. (B) Schematic of proteomic techniques used to quantify biomarker expression in organoids.

also emphasized the importance of using proteomic profiling in addition to transcriptomic analysis in personalized medicine studies using patient-derived organoids. It is noteworthy that organoid proteomics is far more underway than organoid metabolomics (see Species-specific enhancement of enterohemorrhagic *E. coli* pathogenesis mediated by microbiome metabolites for an example of the latter [48]). We believe that a key reason may be that metabolomics (in addition to being less established than proteomics in general) is almost always performed with conventional LC–MS systems, which is limited regarding small samples. Could smaller systems be used for organoid metabolomics? Perhaps, considering that small-scale LC metabolomics has success in recent small-sample applications [49, 50].

However, we predict a need for even more sensitive analytical techniques than “regular” nano-LC. As with the larger i.d. systems, regular nano-LC columns are typically packed with porous particles that feature a hydrophobic stationary phase. As a result of technological development, the particles used today are around 2 μm in size, as opposed to 3–5 μm about 10–15 years ago. Smaller particles are associated with improved chromatography, but generate high back-pressures that require dedicated solvent delivery pumps. In addition, when particles are too small, frictional heating effects and par-

ticle stability can become factors. Therefore, particle-based columns are somewhat of a bottleneck for small-sample analysis, e.g. place limits on how narrow a separation column can be. An alternative to packed columns may be using open tubular LC (OTLC). OTLC columns, which are significantly smaller in scale compared to nano-LC are quite rarely used. An OTLC column is between 5 and 10 μm i.d., and operates at pL-low nL/min flow rates. This makes OTLC highly demanding to operate, but benefits include excellent chromatography and sensitivity. For example, Vehus et al. were able to detect attogram-scale amounts of metabolites using a 10 μm i.d. OTLC column, which were about two orders better compared to other reports with larger columns. The authors also showed that OTLC columns are versatile, with the same column performing well for bottom-up as well as top-down analysis of proteins. OTLC columns are also highly suited for coupling with online sample preparation, e.g. SPE for removing salts and other potential contaminations, and immobilized enzyme reactors for more automated proteomics [51]. In other words, OTLC is a potential candidate for coupling with organoid-related analysis, but is very far from being considered a routine tool.

Other open tubular options include CE. CE has long been known for its excellent separation properties. It is also

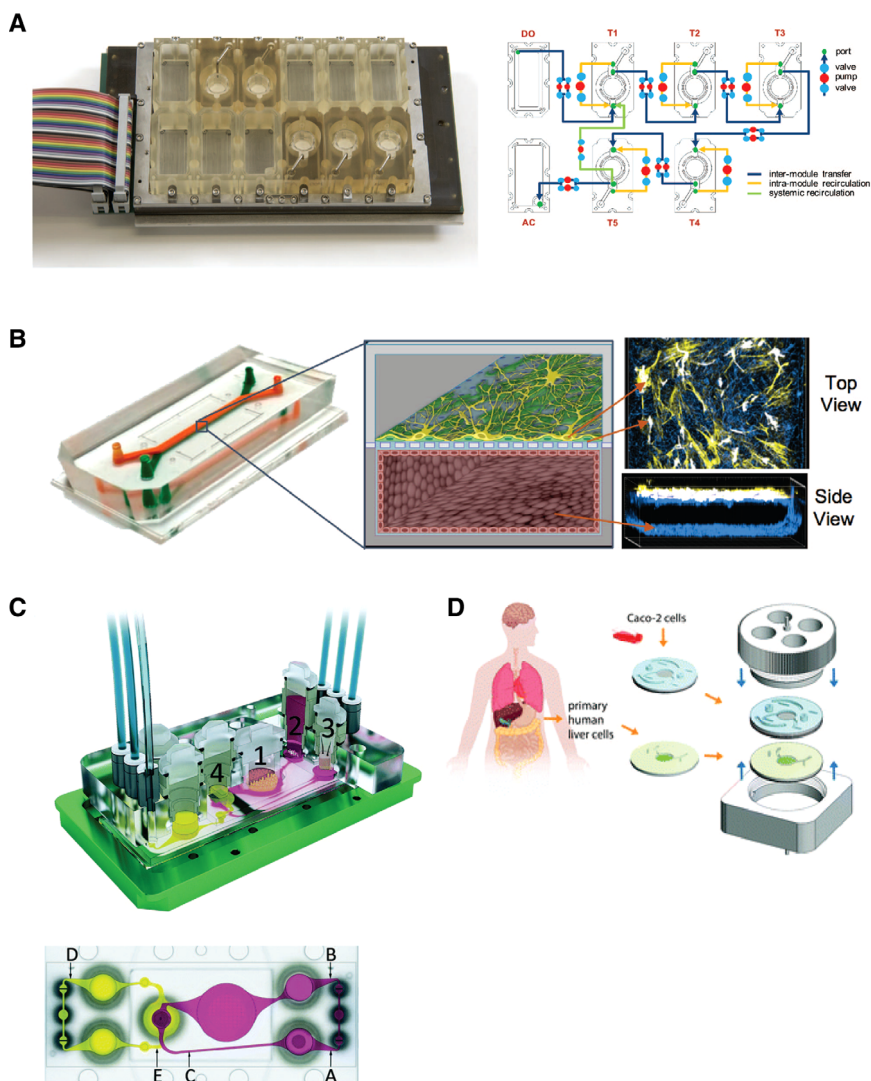

Figure 2. (A) EVATAR, a microfluidic culture model of the human reproductive tract. Images are from ref.64; see also ref.65. (B) Reconstitution of the human blood brain barrier, in an organ chip microfluidic device. Photograph (left), schematic illustration (middle), and immunofluorescence micrographs are from “Hypoxia-enhanced Blood-Brain Barrier Chip recapitulates human barrier function, drug penetration, and antibody shuttling properties” [66]. Preproduced with permission from the authors (the copyright holders of this BiorXiv preprint). (C) Top: Microfluidic device of a four-organ system representing the excretory system, which includes intestine (1), liver (2), skin (3), and kidney (4) tissue. Bottom: Horizontal view of the chip displaying three points of measurement (A, B, and C) in the surrogate blood circuit and two points of measurement (D, E) in the excretory circuit. Images are from “A four-organ-chip for interconnected long-term co-culture of human intestine, liver, skin and kidney equivalents” [67]; Reproduced by permission of The Royal Society of Chemistry. (D) Organ-on-CHIP containing co-culture of gastric intestinal tract epithelium and 3D primary liver tissue. Images are from “Modular, pumpless body-on-a-chip platform for the co-culture of GI tract epithelium and 3D primary liver tissue” [68]; Reproduced by permission of The Royal Society of Chemistry.

commonly associated with chip-based systems [52, 53]. Although CE in many instances out-competed LC in terms of separation capabilities, the latter has been the tool of choice for most bio-analysts. A key reason may be that LC is compatible with ESI-MS, while the electrolyte solutions of CE have been far more difficult to couple with MS detection. However, CE-ESI-MS can prove highly sensitive analysis. In addition, it has been shown that CE-ESI-MS has excellent potential for analysis of intact proteins [54, 55], fulfilling a prediction by James Jorgenson in his pioneering work in developing CE. Considering that CE is capable of, e.g. drug analysis [56], metabolomics [57], proteomics [58], and is “chip-ready”, CE could very well be a natural partner in organoid analysis.

4 On-chip technology: challenges and opportunities for online MS analysis

Major advantages of microfluidic devices include automatable manipulation and on-line or “on chip” analysis (see

Fig. 2). On-line is a highly familiar term to analysts and separation scientists, as well as the associated pro’s and con’s. Advantages of online action can include rapid and precise analysis, with reduced chances of outside contaminations. Disadvantages can include decreased flexibility, poor robustness due to clogging and incompatibility of solvents when two or more fluidic systems are to be hyphenated [59]. It is therefore possible that all these traits will be present when organ-on-a-chip and nano-LC-MS are to be coupled on-line. For example, the organ-on-a-chip will typically have an oxygenated medium consisting of, e.g. salts and serum, components that can cause interferences in LC-MS. Therefore, a modulation system for bridging the OoC system to the nano-LC-MS system can be necessary. A system by Elisabeth Verpoorte and co-workers for drug metabolism studies of liver slices will be a likely template (Figure 3) [60]. Here, a medium fraction is sent to one storage loop, while a previously “looped” fraction is sent to an LC-UV system for measuring metabolites. Such a modulation system allows for two solvent systems to operate simultaneously without a large degree of mixing. These

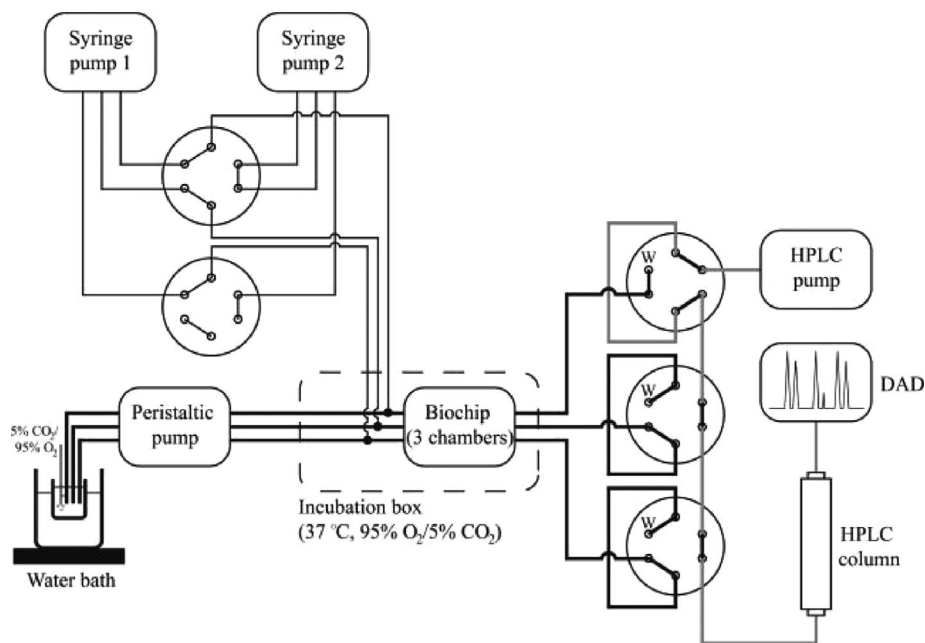

Figure 3. System for metabolism and inhibition studies of precision-cut liver slices in a microfluidic device, online coupled with LC. Preproduced with permission from “On-line HPLC analysis system for metabolism and inhibition studies in precision-cut liver slices” [60]. Copyright (2019) American chemical society.

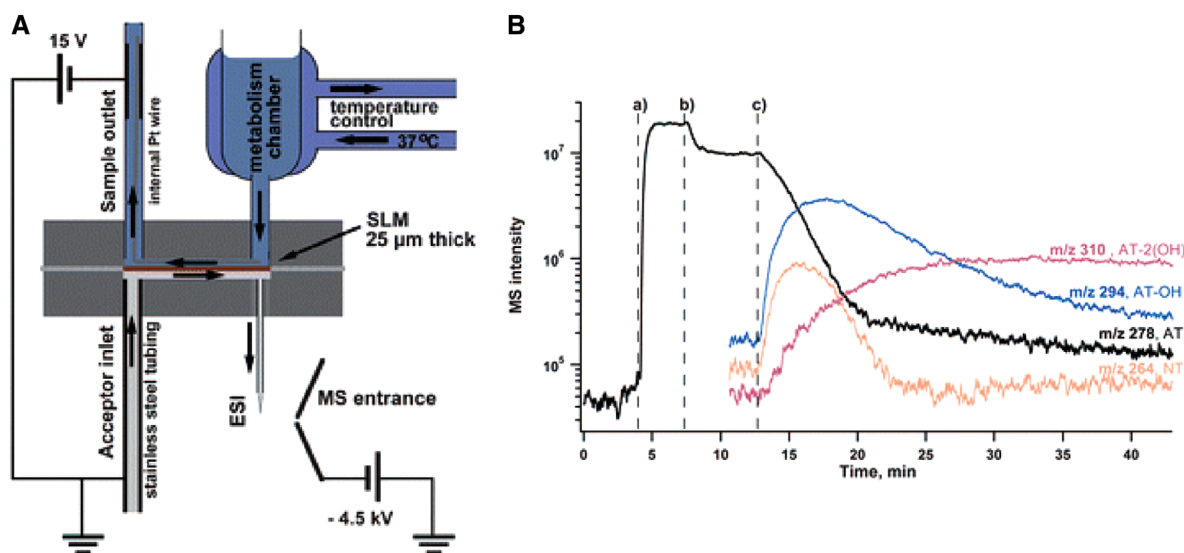

Figure 4. System for the online monitoring of microsome drug metabolism-MS directly with on-chip electromembrane extraction. Image from “On-chip electromembrane extraction for monitoring drug metabolism in real time by ESI-MS” [63]. Reproduced by permission of The Royal Society of Chemistry.

systems remind of 2D LC systems. The described system should be well suited for miniaturization to narrow columns and for MS detection. In addition, more variants can be tested, for example replacing the loops with SPE columns for even more selective handling [61].

However, both the loop and SPE variant may be prone to clogging and perturbing from media proteins, e.g. a relatively high concentration of albumin. Therefore, alternatives to the 2-stage chromatography approaches systems can be investigated. One option is online electromembrane extraction (EME) systems. Fundamentally, EME can be considered as electrophoresis across an oil membrane, and there has been

considerable interest for this concept in recent years [62]. Figure 4A exemplifies the potential, where EME was used in combination with ESI-MS for continuous and on-line monitoring of microsome drug metabolism [63]. In-vitro metabolism of drug substances was performed in a small temperature-controlled metabolism chamber, open to air and located on a microchip for EME. During the metabolic reaction, reaction mixture was continuously perfused at 20 $\mu\text{L}/\text{min}$ into the microchip. Inside the EME microchip, the reaction mixture was in contact with a supported liquid membrane (SLM), comprised of 0.2 μL of 2-nitrophenyl octyl ether immobilized in the pore of a porous membrane of

polypropylene (25 µm thickness). On the other side of the SLM, 100 mM formic acid was pumped continuously with a flow rate of 20 µL/min. This liquid served as acceptor phase. A DC electrical potential was applied across the SLM using small platinum wires in reaction mixture and acceptor phase, and these were connected to an external power supply. By application of 15 V, parent drug substance and metabolites in the reaction mixture were prone to electro-kinetic migration, and were extracted across the SLM and into the acceptor phase. The acceptor phase was pumped continuously into the mass spectrometer, and by such the concentration of parent drug and metabolites were monitored unremittingly as shown in Figure 4B. Buffer components, enzymes, proteins, and other species from the rat liver microsomes used in the reaction mixture were effectively discriminated by the lipophilic SLM, and these matrix components were not introduced into the mass spectrometer. Thus, contamination of the mass spectrometer and serious ion suppression was avoided. We believe that the online EME concept, which has been demonstrated with microsomes and metabolism studies, can be transferred to organoid analysis as well.

5 Concluding remarks

Organoids and organ-on-a-chip systems are predicted to be the key tools in drug discovery and disease modeling in the upcoming years. The limited amounts of sample and on-line features, along with the need for versatile and comprehensive analysis, points to a natural partnership with mass spectrometry and separation science (especially miniaturized systems). Various omics approaches are already being undertaken off-line, but there are especially many opportunities for online coupling. Online organ-on-a-chip MS will be most straightforward for small molecules, e.g. drugs and metabolites. Online proteomics will be more challenging, as protein cleavage to MS-detectable peptides must likely be done in reactors. Immobilized enzyme reactors are indeed available, but are far from becoming routine and robust tools for high throughput organoid analysis.

Finally, we would like to comment on how the output of complete organoid/analysis systems will be handled. Another way in which organ-on-a-chip is distinguished from standard life science experiments is much of the experiment is defined in digital form. For example, chip design is typically defined in CAD files that are sent to 3D printers. Similarly, both on board and offline sensors process signals to record information in digital format. This provides exciting opportunities in how data can be utilized in the organ-on-a-chip universe. In standard life science experiments, data analysis is performed after an experiment has been completed and the processed results are then used to answer a specific scientific question. In the organ-on-a-chip universe, the data encompasses the entire process, from component and experimental design to raw sensor data and processed experimental results. If data can be integrated through introduction of well-defined standards, it becomes feasible to consider artificial intelligence

approaches that allow data to be used in a feedback process. In such an approach data could be used to iteratively introduce design modifications (for example, changes to chip profiles or sensor/chip/cell combinations) that leads to optimised designs for specific purposes.

Financial support from UiO:Life Science is gratefully acknowledged. This work was also partially supported by the Research Council of Norway through its Centre of Excellence scheme, project number 262613. This work has also received financial support from the Olav Thon Foundation and the US-Norway Fulbright Foundation.

The authors have declared no conflict of interest.

6 References

- [1] Scannell, J. W., Blanckley, A., Boldon, H., Warrington, B., *Nat. Rev. Drug Discov.* 2012, 11, 191–200.
- [2] Roy, A., *High-Throughput* 2018, 7, 4.
- [3] Hwang, T. J., Carpenter, D., Lauffenburger, J. C., Wang, B., Franklin, J. M., Kesselheim, A. S., *JAMA Intern. Med.* 2016, 176, 1826–1833.
- [4] Fogel, D. B., *Contemp. Clin. Trials Commun.* 2018, 11, 156–164.
- [5] Wong, C. H., Siah, K. W., Lo, A. W., *Biostatistics* 2019, 20, 273–286.
- [6] Jodat, Y. A., Kang, M. G., Kiaee, K., Kim, G. J., Martinez, A. F. H., Rosenkranz, A., Bae, H., Shin, S. R., *Curr. Pharm. Des.* 2018, 24, 5471–5486.
- [7] Ishida, S., *Drug Metab. Pharmacokinet.* 2018, 33, 49–54.
- [8] Li, M., Izpisua Belmonte, J. C., *N. Engl. J. Med.* 2019, 380, 569–579.
- [9] Whitesides, G. M., *Nature* 2006, 442, 368–373.
- [10] Sosa-Hernández, J. E., Villalba-Rodríguez, A. M., Romero-Castillo, K. D., Aguilar-Aguila-Isaías, M. A., García-Reyes, I. E., Hernández-Antonio, A., Ahmed, I., Sharma, A., Parra-Saldívar, R., Iqbal, H. M. N., *Micromachines (Basel)*. 2018, 9, pii: E536.
- [11] Kimura, H., Sakai, Y., Fujii, T., *Drug Metab. Pharmacokinet.* 2018, 33, 43–48.
- [12] Zhang, B., Radisic, M., *Lab Chip* 2017, 17, 2395–2420.
- [13] Zhang, M., Xu, C., Jiang, L., Qin, J., *Toxicol. Res.* 2018, 7, 1048–1060.
- [14] Stucki, A. O., Stucki, J. D., Hall, S. R., Felder, M., Mermoud, Y., Schmid, R. A., Geiser, T., Guenat, O. T., *Lab Chip* 2015, 15, 1302–1310.
- [15] Bein, A., Shin, W., Jalili-Firoozinezhad, S., Park, M. H., Sontheimer-Phelps, A., Tovaglieri, A., Chalkiadaki, A., Kim, H. J., Ingber, D. E., *Cell. Mol. Gastroenterol. Hepatol.* 2018, 5, 659–668.
- [16] Helm, M. W. van der, Henry, O. Y. F., Bein, A., Hamkins-Indik, T., Crouce, M. J., Leineweber, W. D., Odijk, M., Meer, A. D. van der, Eijkel, J. C. T., Ingber, D. E., Berg, A. van den, Segerink, L. I., *Lab Chip* 2019, 19, 452–463.
- [17] Haring, A. P., Sontheimer, H., Johnson, B. N., *Stem Cell Rev. Rep.* 2017, 13, 381–406.
- [18] Miccoli, B., Braeken, D., Li, Y.-C. E., *Curr. Pharm. Des.* 2018, 24, 5419–5436.

- [19] Agarwal, A., Goss, J. A., Cho, A., McCain, M. L., Parker, K. K., *Lab Chip* 2013, **13**, 3599–3608.
- [20] Wan, H., Gu, C., Gan, Y., Wei, X., Zhu, K., Hu, N., Wang, P., *Curr. Pharm. Des.* 2018 **24**, 5375–5385.
- [21] Danoy, M., Bernier, M. L., Kimura, K., Poulain, S., Kato, S., Mori, D., Kido, T., Plessy, C., Kusuhara, H., Miyajima, A., Sakai, Y., Leclerc, E., *Biotechnol. Bioeng.* 2019, **116**, 1762–1776.
- [22] Camp, J. G., Sekine, K., Gerber, T., Loeffler-Wirth, H., Binder, H., Gac, M., Kanton, S., Kageyama, J., Damm, G., Seehofer, D., Belicova, L., Bickle, M., Barsacchi, R., Okuda, R., Yoshizawa, E., Kimura, M., Ayabe, H., Taniguchi, H., Takebe, T., Treutlein, B., *Nature* 2017, **546**, 533–538.
- [23] Tao, T., Wang, Y., Chen, W., Li, Z., Su, W., Guo, Y., Deng, P., Qin, J., *Lab Chip* 2019, **19**, 948–958.
- [24] Loskill, P., Sezhian, T., Tharp, K. M., Lee-Montiel, F. T., Jeeawoody, S., Reese, W. M., Zushin, P.-J. H., Stahl, A., Healy, K. E., *Lab Chip* 2017, **17**, 1645–1654.
- [25] Chen, H. J., Miller, P., Shuler, M. L., *Lab Chip* 2018, **18**, 2036–2046.
- [26] Oleaga, C., Riu, A., Rothemund, S., Lavado, A., McAleer, C. W., Long, C. J., Persaud, K., Narasimhan, N. S., Tran, M., Roles, J., Carmona-Moran, C. A., Sasserath, T., Elbrecht, D. H., Kumanchik, L., Bridges, L. R., Martin, C., Schaeffer, M. T., Ekman, G., Jackson, M., Wang, Y. I., Note, R., Langer, J., Teissier, S., Hickman, J. J., *Biomaterials* 2018, **182**, 176–190.
- [27] Nguyen, M., De Ninno, A., Mencattini, A., Mermet-Meillon, F., Fornabaio, G., Evans, S. S., Cossutta, M., Khira, Y., Han, W., Sirven, P., Pelon, F., Di Giuseppe, D., Bertani, F. R., Gerardino, A., Yamada, A., Descroix, S., Soumelis, V., Mechta-Grigoriou, F., Zalcmann, G., Camonis, J., Martinelli, E., Businaro, L., Parrini, M. C., *Cell Rep.* 2018, **25**, 3884–3893.e3.
- [28] Karagiannis, P., Takahashi, K., Saito, M., Yoshida, Y., Okita, K., Watanabe, A., Inoue, H., Yamashita, J. K., Todani, M., Nakagawa, M., Osawa, M., Yashiro, Y., Yamanaka, S., Osafune, K., *Physiol. Rev.* 2019, **99**, 79–114.
- [29] Shinozawa, T., Yoshikawa, H. Y., Takebe, T., *Dev. Biol.* 2016, **420**, 221–229.
- [30] Eiraku, M., Watanabe, K., Matsuo-Takasaki, M., Kawada, M., Yonemura, S., Matsumura, M., Wataya, T., Nishiyama, A., Muguruma, K., Sasai, Y., *Cell Stem Cell* 2008, **3**, 519–532.
- [31] Coll, M., Perea, L., Boon, R., Leite, S. B., Vallverdú, J., Mannaerts, I., Smout, A., El Taghdouini, A., Blaya, D., Rodrigo-Torres, D., Graupera, I., Aguilar-Bravo, B., Chesne, C., Najimi, M., Sokal, E., Lozano, J. J., Grunsvén, L. A. van, Verfaillie, C. M., Sancho-Bru, P., *Cell Stem Cell* 2018, **23**, 101–113.e7.
- [32] Takebe, T., Enomura, M., Yoshizawa, E., Kimura, M., Koike, H., Ueno, Y., Matsuzaki, T., Yamazaki, T., Toyohara, T., Osafune, K., Nakauchi, H., Yoshikawa, H. Y., Taniguchi, H., *Cell Stem Cell* 2015, **16**, 556–565.
- [33] Huch, M., Dorrell, C., Boj, S. F., Es, J. H. van, Li, V. S. W., Wetering, M. van de, Sato, T., Hamer, K., Sasaki, N., Finegold, M. J., Haft, A., Vries, R. G., Grompe, M., Clevers, H., *Nature* 2013, **494**, 247–250.
- [34] Lancaster, M. A., Renner, M., Martin, C.-A., Wenzel, D., Bicknell, L. S., Hurlles, M. E., Homfray, T., Penninger, J. M., Jackson, A. P., Knoblich, J. A., *Nature* 2013, **501**, 373–379.
- [35] Jo, J., Xiao, Y., Sun, A. X., Cukuroglu, E., Tran, H.-D., Göke, J., Tan, Z. Y., Saw, T. Y., Tan, C.-P., Lokman, H., Lee, Y., Kim, D., Ko, H. S., Kim, S.-O., Park, J. H., Cho, N.-J., Hyde, T. M., Kleinman, J. E., Shin, J. H., Weinberger, D. R., Tan, E. K., Je, H. S., Ng, H.-H., *Cell Stem Cell* 2016, **19**, 248–257.
- [36] Qian, X., Nguyen, H. N., Song, M. M., Hadiono, C., Ogden, S. C., Hammack, C., Yao, B., Hamersky, G. R., Jacob, F., Zhong, C., Yoon, K.-J., Jeang, W., Lin, L., Li, Y., Thakor, J., Berg, D. A., Zhang, C., Kang, E., Chickering, M., Nauen, D., Ho, C.-Y., Wen, Z., Christian, K. M., Shi, P.-Y., Maher, B. J., Wu, H., Jin, P., Tang, H., Song, H., Ming, G.-L., *Cell* 2016, **165**, 1238–1254.
- [37] Marchetto, M. C. N., Carromeu, C., Acab, A., Yu, D., Yeo, G. W., Mu, Y., Chen, G., Gage, F. H., Muotri, A. R., *Cell* 2010, **143**, 527–539.
- [38] Spence, J. R., Mayhew, C. N., Rankin, S. A., Kuhar, M. F., Vallance, J. E., Tolle, K., Hoskins, E. E., Kalinichenko, V. V., Wells, S. I., Zorn, A. M., Shroyer, N. F., Wells, J. M., *Nature* 2011, **470**, 105–109.
- [39] Sato, T., Vries, R. G., Snippert, H. J., Wetering, M. van de, Barker, N., Stange, D. E., Es, J. H. van, Abo, A., Kujala, P., Peters, P. J., Clevers, H., *Nature* 2009, **459**, 262–265.
- [40] Wells, J. M., Spence, J. R., *Development* 2014, **141**, 752–760.
- [41] Guan, Y., Xu, D., Garfin, P. M., Ehmer, U., Hurwitz, M., Enns, G., Michie, S., Wu, M., Zheng, M., Nishimura, T., Sage, J., Peltz, G., *JCI Insight.* 2017, **2**, 94954.
- [42] Wilson, S. R., Vehus, T., Berg, H. S., Lundanes, E., *Bioanalysis* 2015, **7**, 1799–1815.
- [43] Dakic, V., Minardi Nascimento, J., Costa Sartore, R., Maciel, R. de M., Araujo, D. B. de, Ribeiro, S., Martins-de-Souza, D., Rehen, S. K., *Sci. Rep.* 2017, **7**, 12863.
- [44] Lindeboom, R. G., Voorthuisen, L. van, Oost, K. C., Rodríguez-Colman, M. J., Luna-Velez, M. V., Furlan, C., Baraille, F., Jansen, P. W., Ribeiro, A., Burgering, B. M., Snippert, H. J., Vermeulen, M., *Mol. Syst. Biol.* 2018, **14**, e8227.
- [45] Williams, K. E., Lemieux, G. A., Hassis, M. E., Olshen, A. B., Fisher, S. J., Werb, Z., *Proc. Natl. Acad. Sci. USA* 2016, **113**, E1343–E1351.
- [46] Boj, S. F., Hwang, C.-I., Baker, L. A., Chio, I. I. C., Engle, D. D., Corbo, V., Jager, M., Ponz-Sarvisé, M., Tiriác, H., Spector, M. S., Gracanin, A., Oni, T., Yu, K. H., van Boxtel, R., Huch, M., Rivera, K. D., Wilson, J. P., Feigin, M. E., Öhlund, D., Handly-Santana, A., Ardito-Abraham, C. M., Ludwig, M., Elyada, E., Alagesan, B., Biffi, G., Yordanov, G. N., Delcuze, B., Creighton, B., Wright, K., Park, Y., Morsink, F. H. M., Molenaar, I. Q., Borel Rinkes, I. H., Cuppen, E., Hao, Y., Jin, Y., Nijman, I. J., Iacobuzio-Donahue, C., Leach, S. D., Pappin, D. J., Hammell, M., Klimstra, D. S., Basturk, O., Hruban, R. H., Offerhaus, G. J., Vries, R. G. J., Clevers, H., Tuveson, D. A., *Cell* 2015, **160**, 324–338.
- [47] Cristobal, A., Toorn, H. W. P. van den, Wetering, M. van de, Clevers, H., Heck, A. J. R., Mohammed, S., *Cell Rep.* 2017, **18**, 263–274.

- [48] Tovaglieri, A., Sontheimer-Phelps, A., Geirnaert, A., Prantil-Baun, R., Camacho, D. M., Chou, D. B., Jalili-Firoozinezhad, S., Wouters, T. de, Kasendra, M., Super, M., Cartwright, M. J., Richmond, C. A., Breault, D. T., Lacroix, C., Ingber, D. E., *Microbiome* 2019, 7, 43.
- [49] Vehus, T., Roberg-Larsen, H., Waaler, J., Aslaksen, S., Krauss, S., Wilson, S. R., Lundanes, E., *Sci. Rep.* 2016, 6, 37507.
- [50] Roberg-Larsen, H., Lund, K., Seterdal, K. E., Solheim, S., Vehus, T., Solberg, N., Krauss, S., Lundanes, E., Wilson, S. R., *J. Steroid Biochem. Mol. Biol.* 2017, 169, 22–28.
- [51] Hustoft, H. K., Vehus, T., Brandtzaeg, O. K., Krauss, S., Greibrokk, T., Wilson, S. R., Lundanes, E., *PLoS One* 2014, 9, e106881.
- [52] Benz, C., Boomhoff, M., Appun, J., Schneider, C., Belder, D., *Angew. Chem., Int. Ed.* 2015, 54, 2766–2770.
- [53] Wu, D., Qin, J., Lin, B., *J. Chromatogr. A* 2008, 1184, 542–559.
- [54] Zhao, Y., Sun, L., Zhu, G., Dovichi, N. J., *J. Proteome Res.* 2016, 15, 3679–3685.
- [55] Lubeckyj, R. A., McCool, E. N., Shen, X., Kou, Q., Liu, X., Sun, L., *Anal. Chem.* 2017, 89, 12059–12067.
- [56] Langmajerová, M., Řemínek, R., Pelcová, M., Foret, F., Glatz, Z., *Electrophoresis* 2015, 36, 1365–1373.
- [57] Ramautar, R., Somsen, G. W., Jong, G. J. de, *Electrophoresis* 2017, 38, 190–202.
- [58] Heemskerk, A. A. M., Deelder, A. M., Mayboroda, O. A., *Mass Spectrometry Rev.* 2016, 35, 259–271.
- [59] Rogeberg, M., Malerod, H., Roberg-Larsen, H., Aass, C., Wilson, S. R., *J. Pharm. Biomed. Anal.* 2014, 87, 120–129.
- [60] Midwoud, P. M. van, Janssen, J., Merema, M. T., Graaf, I. A. M. de, Groothuis, G. M. M., Verpoorte, E., *Anal. Chem.* 2011, 83, 84–91.
- [61] Malerod, H., Lundanes, E., Greibrokk, T., *Anal. Meth.* 2010, 2, 110–122.
- [62] Huang, C., Chen, Z., Gjelstad, A., Pedersen-Bjergaard, S., Shen, X., *Trends Anal. Chem.* 2017, 95, 47–56.
- [63] Petersen, N. J., Pedersen, J. S., Poulsen, N. N., Jensen, H., Skonberg, C., Hansen, S. H., Pedersen-Bjergaard, S., *Analyst* 2012, 137, 3321–3327.
- [64] EVATAR TECHNOLOGY | Woodruff Lab <https://www.woodrufflab.org/EvatarTechnology> [accessed Apr 15, 2019].
- [65] Xiao, S., Coppeta, J. R., Rogers, H. B., Isenberg, B. C., Zhu, J., Olalekan, S. A., McKinnon, K. E., Dokic, D., Rashedi, A. S., Haisenleder, D. J., Malpani, S. S., Arnold-Murray, C. A., Chen, K., Jiang, M., Bai, L., Nguyen, C. T., Zhang, J., Laronda, M. M., Hope, T. J., Maniar, K. P., Pavone, M. E., Avram, M. J., Sefton, E. C., Getsios, S., Burdette, J. E., Kim, J. J., Borenstein, J. T., Woodruff, T. K., *Nat. Commun.* 2017, 8, 14584.
- [66] Park, T.-E., Mustafaoglu, N., Herland, A., Hasselkus, R. M., Mannix, R., FitzGerald, E. A., Prantil-Baun, R., Watters, A., Henry, O., Benz, M., Sanchez, H., McCrea, H. J., Christova Goumnerova, L., Song, H. W., Palecek, S. P., Shusta, E., Ingber, D. E., *bioRxiv* 2018 <https://doi.org/10.1101/482463>.
- [67] Maschmeyer, I., Lorenz, A. K., Schimek, K., Hasenberg, T., Ramme, A. P., Hübner, J., Lindner, M., Drewell, C., Bauer, S., Thomas, A., Sambo, N. S., Sonntag, F., Lauster, R., Marx, U., *Lab Chip* 2015, 15, 2688–2699.
- [68] Esch, M. B., Ueno, H., Applegate, D. R., Shuler, M. L., *Lab Chip* 2016, 16, 2719–2729.